

# ACCESS LAY-BY/PASSING PLACE (householder)

Revision F November 2015

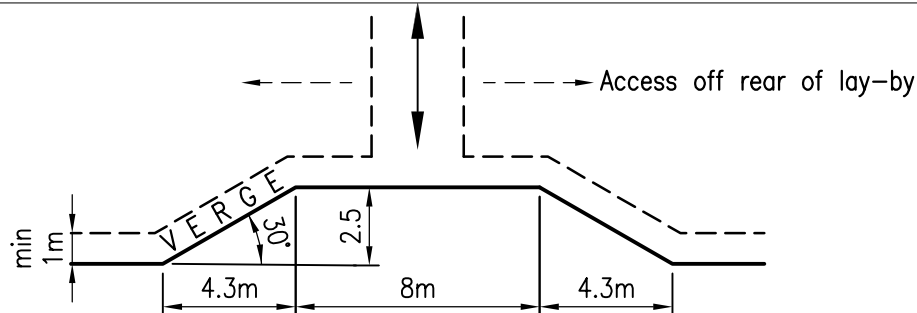

TRANSPORTATION  
COUNCIL OFFICE  
HIGH STREET  
ELGIN IV30 1BX  
TEL: 0300 1234565



**ACCESS LAY-BY FOR A SINGLE DWELLINGHOUSE**

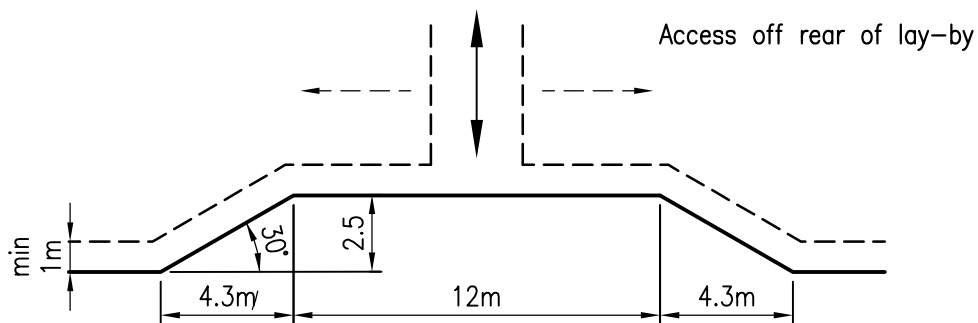

**ACCESS LAY-BY FOR 2 DWELLINGHOUSES**

**Note:**

(xx) Denotes specification for HGV's  
\*\* Denotes Length to be confirmed with The Roads Authority

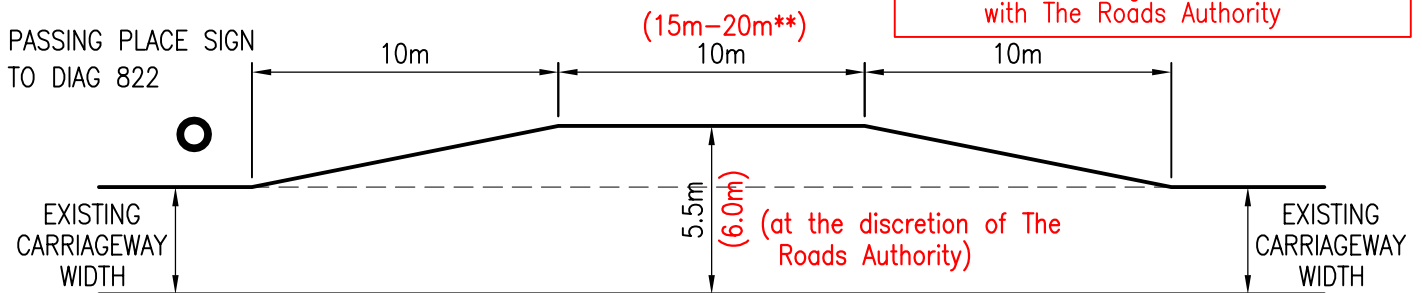

## P A S S I N G P L A C E

### SPECIFICATION FOR PASSING PLACE OR ACCESS LAY-BY ONTO PUBLIC ROAD

1 Groundworks:	Remove all topsoil and unsuitable material; excavate/upfill to meet required level of formation.
2 Type 1 sub-base:	250mm
3 Dense Bituminous Macadam road base:	100mm
4 Dense Bituminous Macadam binder course:	60mm
5 Dense Bituminous Macadam surface course:	40mm

Minimum 1m wide verge around perimeter of lay-by.

Sign specification to be as per The Traffic Signs Regulations and General Directions 2002:  
Sign to Diagram 822 – "Passing Place" back to back on new 76mm diameter pole, 450mm class ref 1.